

(No Model.)

2 Sheets—Sheet 1.

# A. K. LOVELL. WRENCH.

No. 559,901.

Patented May 12, 1896.

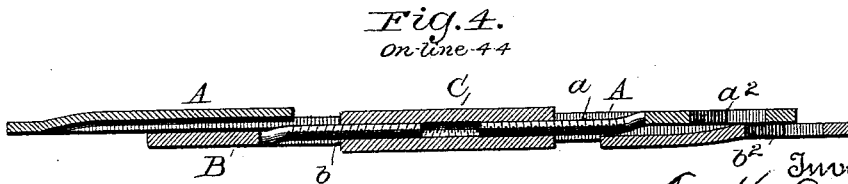
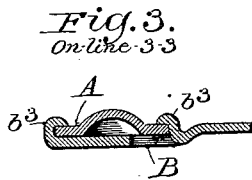
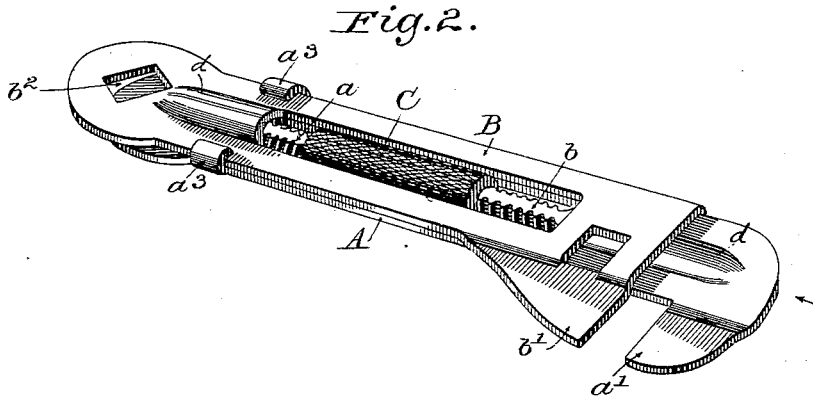
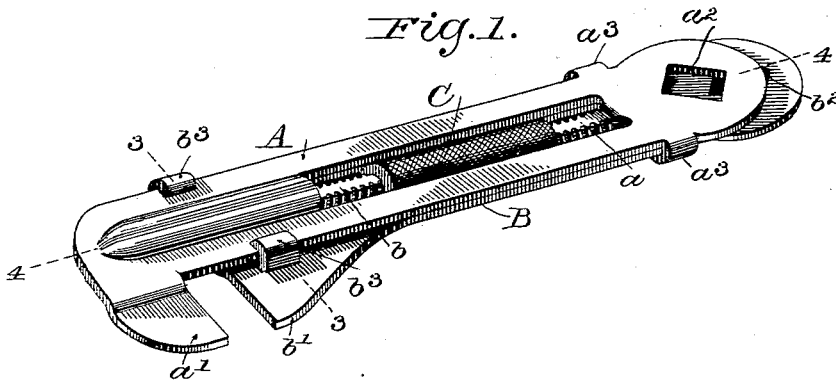

Witnesses

Arthur Ashley  
J. S. Elmer

Inventor  
A. K. Lovell  
B. P. Dodge  
Attorney

A. K. LOVELL.  
WRENCH.

No. 559,901.

Patented May 12, 1896.

Fig. 5.

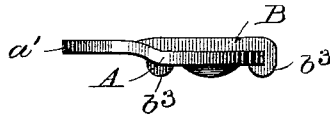

Fig. 6.

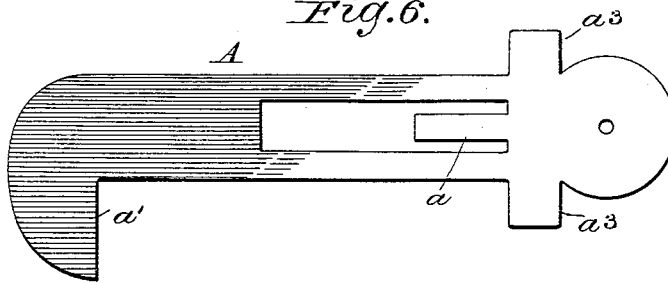

Fig. 7.

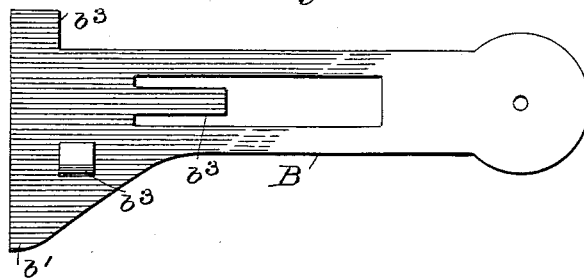
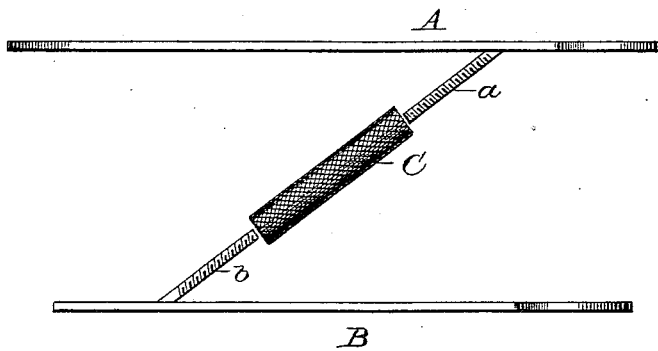

Fig. 8.



Witnesses

Arthur Ashley  
J. S. Elmer

Inventor

A. K. Lovell  
By P. T. Sodge  
Attorneys

# UNITED STATES PATENT OFFICE.

ALBERT KINGMAN LOVELL, OF NEW YORK, N. Y.

## WRENCH.

SPECIFICATION forming part of Letters Patent No. 559,901, dated May 12, 1896.

Application filed December 16, 1895. Serial No. 572,305. (No model.)

*To all whom it may concern:*

Be it known that I, ALBERT KINGMAN LOVELL, of New York city, county of New York, and State of New York, have invented a new and useful Improvement in Wrenches, of which the following is a specification.

The aim of my invention is to produce an adjustable wrench which shall be at once light, cheap, strong, and compact; and to this end it consists in the formation of the wrench-body of two interlocking sliding parts punched from sheet-steel or other suitable metal and permanently united by an intermediate adjusting-nut.

15 In the annexed drawings, Figures 1 and 2 are perspective views of my wrench as seen from opposite sides. Fig. 3 is a cross-section on the line correspondingly numbered in Fig. 1. Fig. 4 is a longitudinal section on the correspondingly-numbered line of Fig. 1. Fig. 5 is an end view of the wrench, looking in the direction indicated by the arrow in Fig. 2, showing the manner in which the jaws on the respective parts are bent in order to bring them in line. Figs. 6 and 7 are views showing the shape of the blanks. Fig. 8 is an edge view of the two members and the nut during a formative stage in the manufacture.

25 In order that the invention may be clearly understood, I will first describe the completed wrench and thereafter the manner of forming and uniting its parts.

Referring to Figs. 1 to 5, inclusive, A and B represent the two complementary parts of my double-ended wrench, connected to slide endwise in relation to each other and adjusted by means of the tubular nut C, receiving the threaded necks *a b* of the other members. The member A is in the form of a flat bar having at one end a laterally-projecting jaw *a'* and at the other end a circular enlargement containing a square hole *a''*. The member B is a flat bar somewhat shorter than its companion with the jaw *b'* at one end and the square opening *b''* at the other. The member A is formed near its smaller end with two lips *a<sup>3</sup>*, which are bent upward from its edges around the edges of part B, which latter is in turn provided near the other end with lips *b<sup>3</sup>*, clasping the edges of part A. These lips formed integral with the parts serve as strong connections between the two parts, holding

them in line and preventing their lateral separation, but permitting them to slide longitudinally in relation to each other. The two parts are slotted longitudinally at the middle to admit the nut C, and the necks *a b*, which enter the nut from opposite ends, are formed integral with the parts A B, respectively, and so threaded that when the nut is turned the necks will both be drawn in or driven out, and thus the main members adjusted to vary the distance between their jaws and also the extent to which the square holes overlap. The adjustment of the jaws of course adapts the wrench to fit nuts or bolts of different sizes. Small bolt-heads may be passed into the square holes in the two members, and by the change in the amount of their overlap and the consequent variation in the size of the opening such heads may be grasped tightly on all four sides. It will be noted in Figs. 1, 2, and 5 that the two jaws are bent or offset sidewise from their bodies in order to bring their active faces in line, or, in other words, directly opposite each other. This of course causes that portion of the jaws nearest the body to stand in an oblique relation to the remainder, so that the width of bearing on the nut is increased. In this manner I avoid danger of indenting or marring the nuts, although using jaws of thin metal. It will be seen that the threaded necks are set bodily to one side of the main portions in order to bring them in line with each other. It will also be observed that ribs or corrugations *d* are pressed outward longitudinally in the two parts A B in order to give them additional stiffness and to afford room for the necks.

The essential features of my construction are mainly the two sheet-metal members having the lips bent up to connect them, the two threaded necks offset to bring them in line, the sliding members with square overlapping holes, the nut applied as shown, and the jaws bent out of line with the body members to face each other; and it is manifest that the parts may be varied in size, shape, and arrangement within the limits of mechanical skill and judgment.

In constructing the parts I prefer to proceed as follows: By suitable punches I cut from flat sheet metal the two blanks shown in Figs. 6 and 7, each bearing the central slot

and the internal neck or stem, the corrugations being produced at the first or second step, as is most convenient. By the piercing die or punch the necks are bent out beyond the sides at an angle of forty-five degrees, more or less, as shown in Fig. 8, in order to expose them for threading. At the same time the square holes are punched. The necks are then compressed and threaded on their edges by squeezing them between suitably-shaped dies, and the ears are bent up at right angles at their outer ends. The prepared nut is then placed between the two necks, as shown in Fig. 8, and screwed upon them. Pressure is then applied until the parts A B are brought together and the neck brought into line between them, and the lips bent over the edges of the two parts. At this or any other suitable stage the jaws are offset from the bodies, as before explained, thus completing the wrench. It will be observed that as the wrench is opened the necks enter the nut, thus shortening the length of the exposed portions and increasing the strength of the wrench. It is obvious that the jaws at one end or the openings at the other may be omitted, and thus a single-ended wrench produced.

Having thus described my invention, what I claim is—

1. A wrench-body composed of two sheet-

metal members substantially as described, having integral therewith jaws, and lips which form a sliding connection between the members. 35

2. The two sheet-metal members having the bent connecting-lips and the threaded necks integral therewith in combination with the adjusting-nut.

3. In a wrench, the two slotted body members having the intermediate threaded necks in combination with the connecting-nut. 40

4. In a wrench, the sheet-metal body members mounted to slide one on the other and having integral jaws bent or offset in reverse directions to bring their faces opposite each other, substantially as described. 45

5. The sheet-metal body members each corrugated, slotted and provided with a threaded neck and with lips to embrace the other member, in combination with the connecting-nut. 50

6. In a wrench two sliding members provided with square overlapping holes whereby the wrench is adapted to grasp the four faces of square nuts of different sizes. 55

In testimony whereof I hereunto set my hand, this 6th day of December, 1895, in the presence of two attesting witnesses.

ALBERT KINGMAN LOVELL.

Witnesses:

G. T. MIATT,

MARGARET DUNN.